

TOP

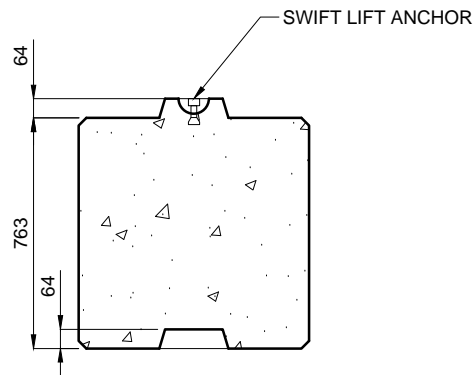

FRONT ELEVATION

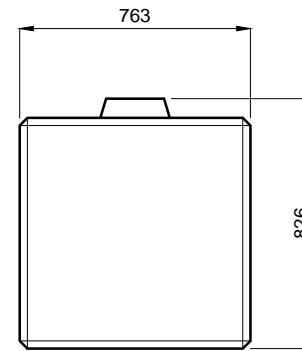

SIDE ELEVATION

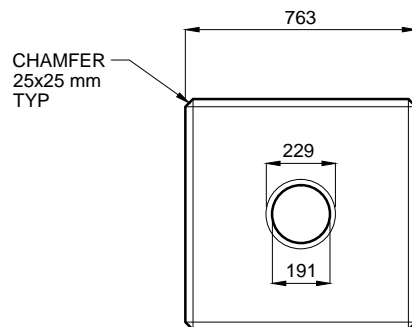

BASE

NOTES

IMPERIAL DIMENSIONS	30"x30"x32.5"
METRIC DIMENSIONS	763x763x826

DRAWING No.# PB - HS

FILE No.# PRECAST BLOCK

Sales Order No.# -

CONCRETE	Volume (cu.m)	Mass (Kg)	Air Content
	0.4	785	5-7%
STRENGTH	Stripping (MPa)	28-days (MPa)	Rebar Grade
	12	32	400W

FINISH : -

HANDLING INSTRUCTIONS -MOVE WITH LIFTING HOOK	REVISION NO.#	-
	REVIEWED BY :	-
	DATE :	-
SCALE :	1:25	
SHEET NO.#	1 of 1	
DRAWN BY :	ED	
DATE :	2016-01-05	