

CONTRACTOR	-
PROJECT NAME	GENERAL
LOCATION	-

PRODUCTION	
PROFILE NO.	BR1-A,B,C,D
TOTAL REQUIRED	-
TOTAL POUR DAYS	-
START POUR DATE	-
PRODUCTION STAMP	SIGN

MOLD	
PROFILE NO.	BR1-A,B,C,D
NO OF MOLDS	3
FABRICATION STAMP	SIGN

REBAR LIST					
MARK	SIZE	SHAPE	No.	LENGTH	WEIGHT
BK42-R10-ST-1	10M		1	967mm	0.75Kg
BK42-R10-BN-2	10M		1	1335mm	1Kg

INSERTS LIST		
TYPE	No.	SHAPE
-	-	

DRAWING No.# BR-42" SU			
FILE No.# BRACKET			
Sales Order No.#			
CONCRETE	Volume (cu.m)	Mass (Kg)	Air Content
	0.025	65	5-7%
STRENGTH	Stripping (MPa)	28-days (MPa)	Rebar Grade
	12	32	400W
FINISH : SMOOTH GREY			

HANDLING INSTRUCTIONS USE FORK LIFT	REVISION NO.#	-
	REVIEWED BY :	-
	DATE :	-
	SCALE :	1:16
SHEET NO.#	1	1
DRAWN BY :	ED	
DATE :	2016-01-27	

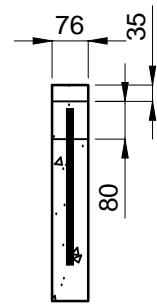

FRONT VIEW

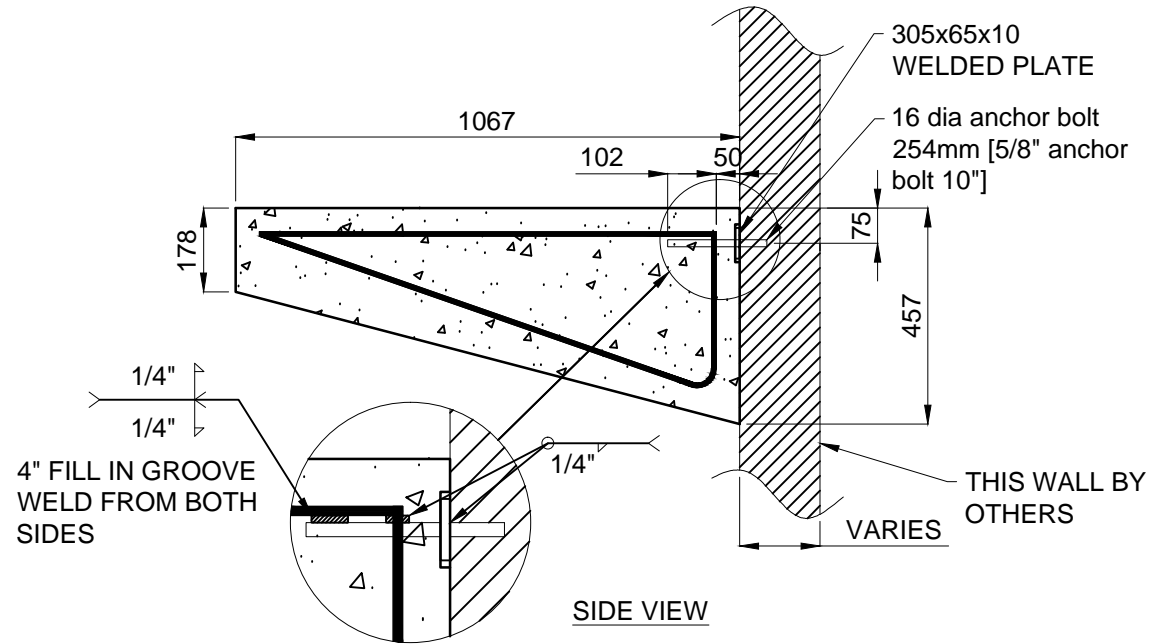

SIDE VIEW

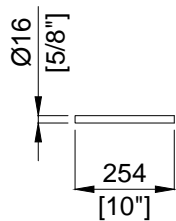

ROD

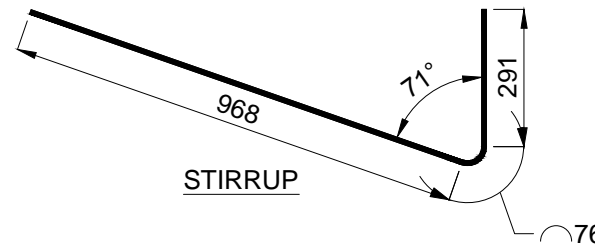

STIRRUP

CONCRETE NOTES:

- Design, mixing, placing and curing of concrete shall conform to CSA 23.1
- Compressive Strength of concrete 32 MPA at 28 days minimum air content of 4%.
- reinforcing steel to conform to CAN/CSA G30.18, Grade 400R
- Clear cover to main reinforcement is 50mm.
- Anchor Bolts, nuts and washers conform to ASTM A307
- Weld to conform to CSA W59, 2003 comply with the CSA W47.1 Division 2. Use minimum 6mm fillet weld.
- The bracket supporting wall shall be structurally stable and designed by others to capable to withstand the overturning moment from the bracket.
- Any super imposed live load, snow load and dead load on top of bracket should not exceed the maximum load indicated in the table according to the bracket size and length.